

Top-level Diagram

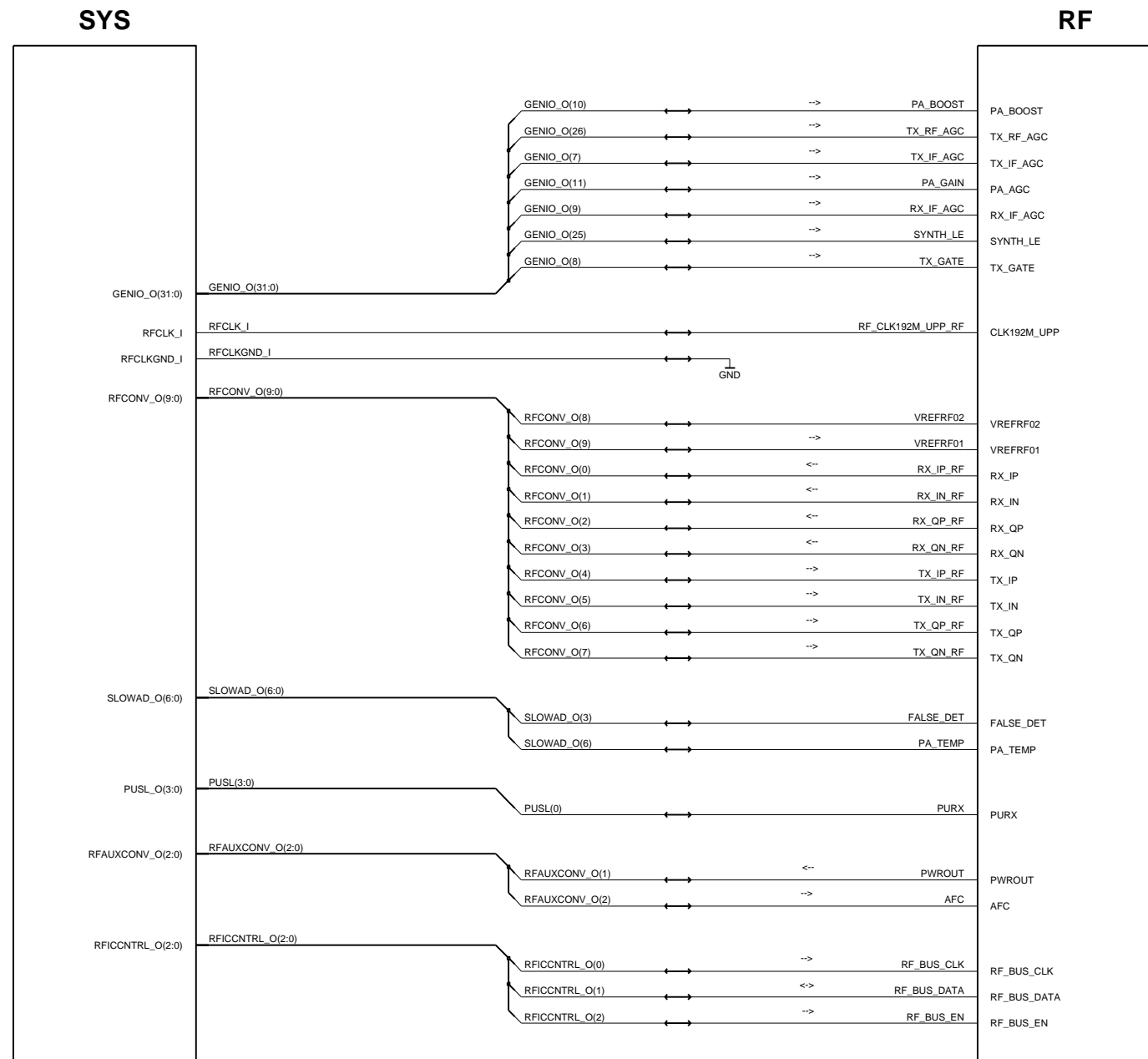

RF Top-level Diagram

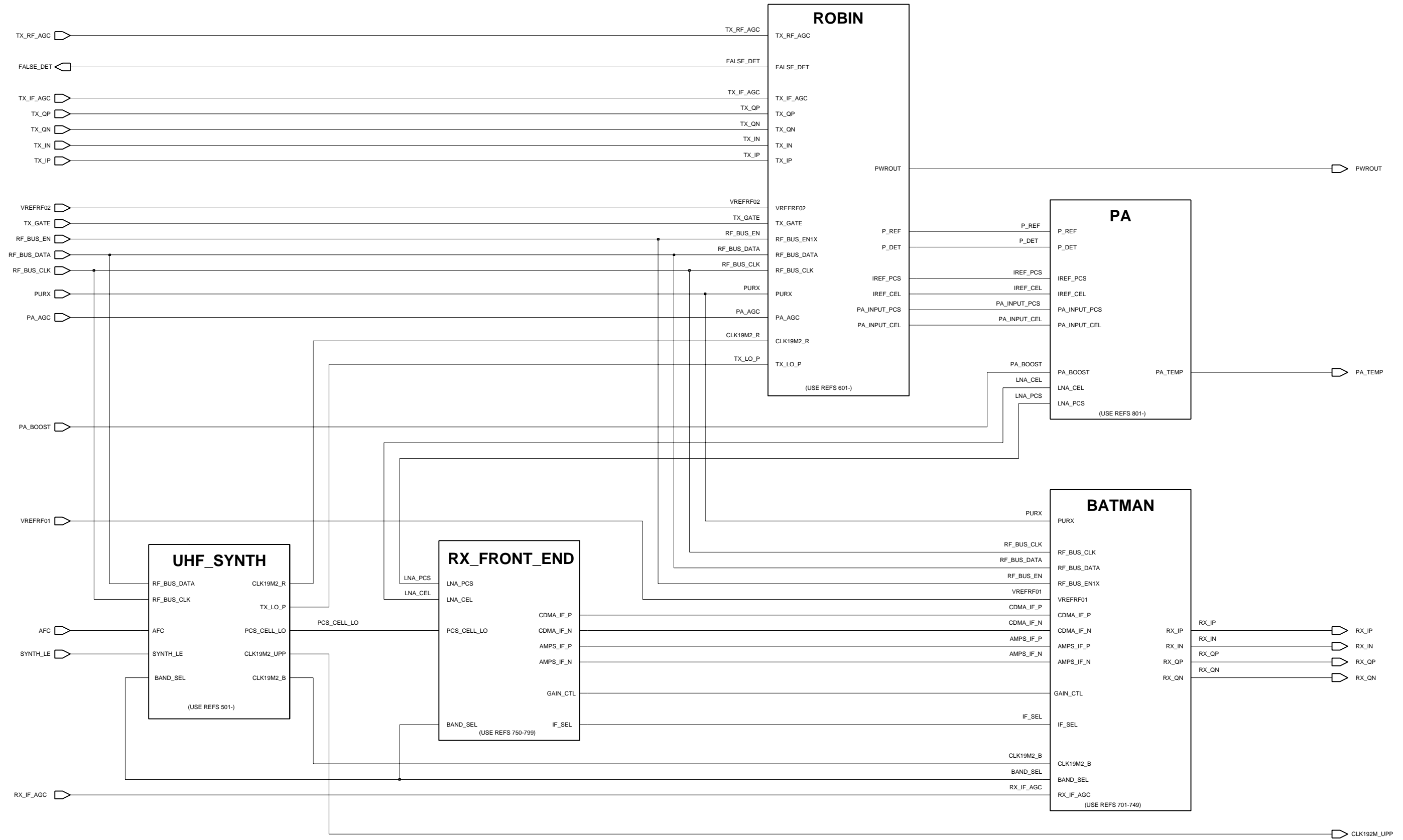

PA

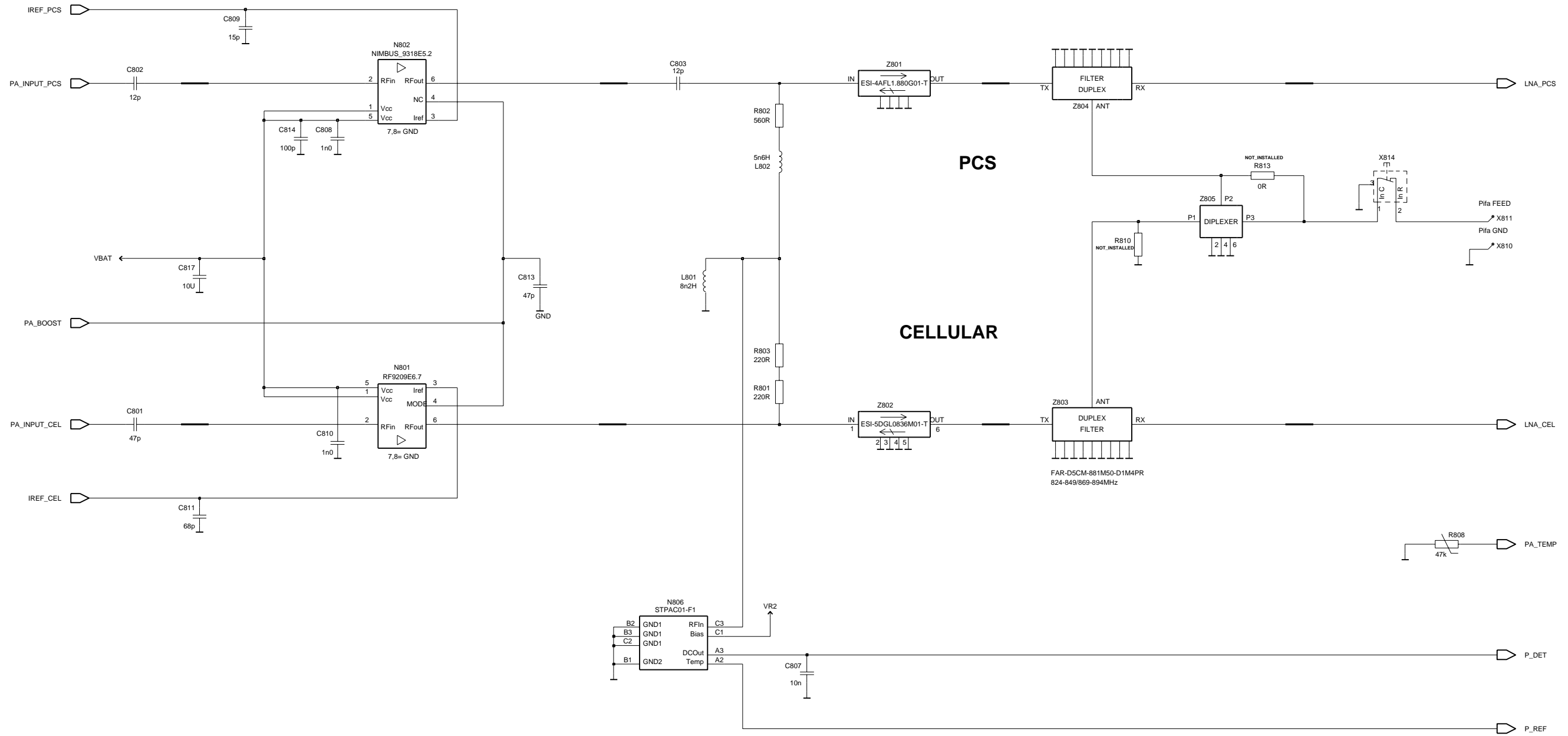

Robin

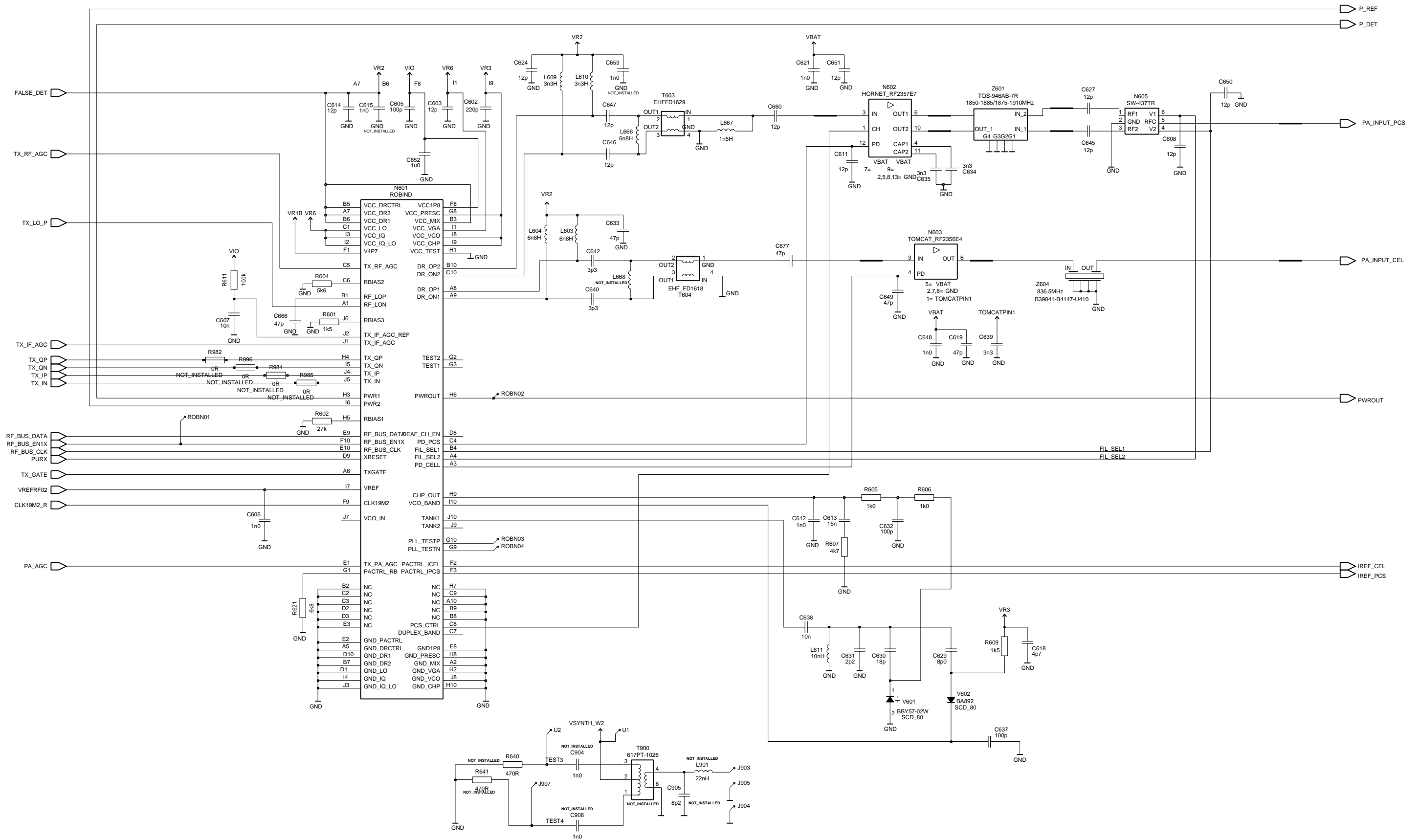

Front End

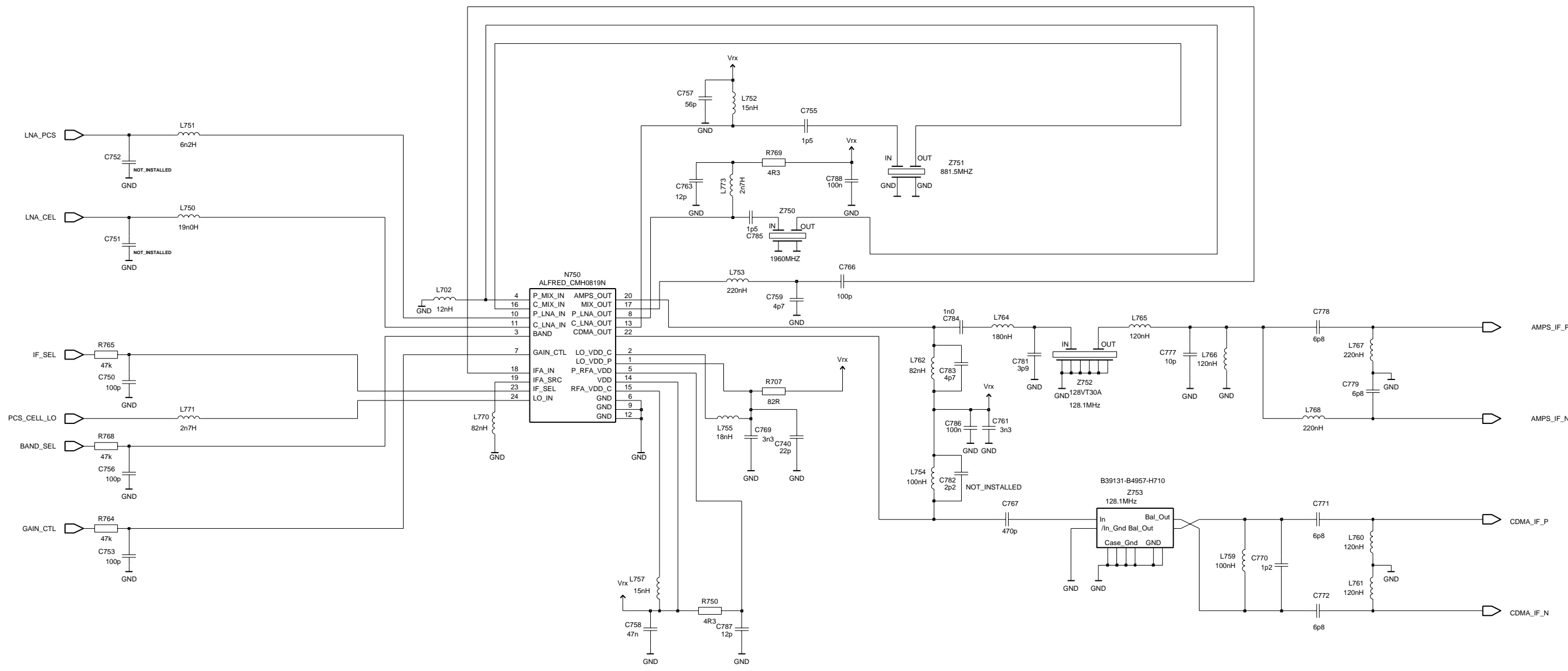
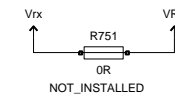

MODES	LOGIC INPUTS		
	BAND	GAIN_CTL	IF_SEL
CEL CDMA Hi Gain	0	1	0
CEL CDMA Lo Gain	0	0	0
PCS CDMA Hi Gain	1	1	0
PCS CDMA Lo Gain	1	0	0
AMPS Hi Gain	0	1	1
AMPS Lo Gain	0	0	1

UHF Synthesizer

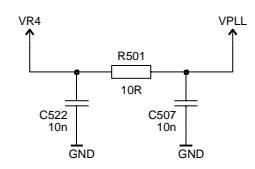
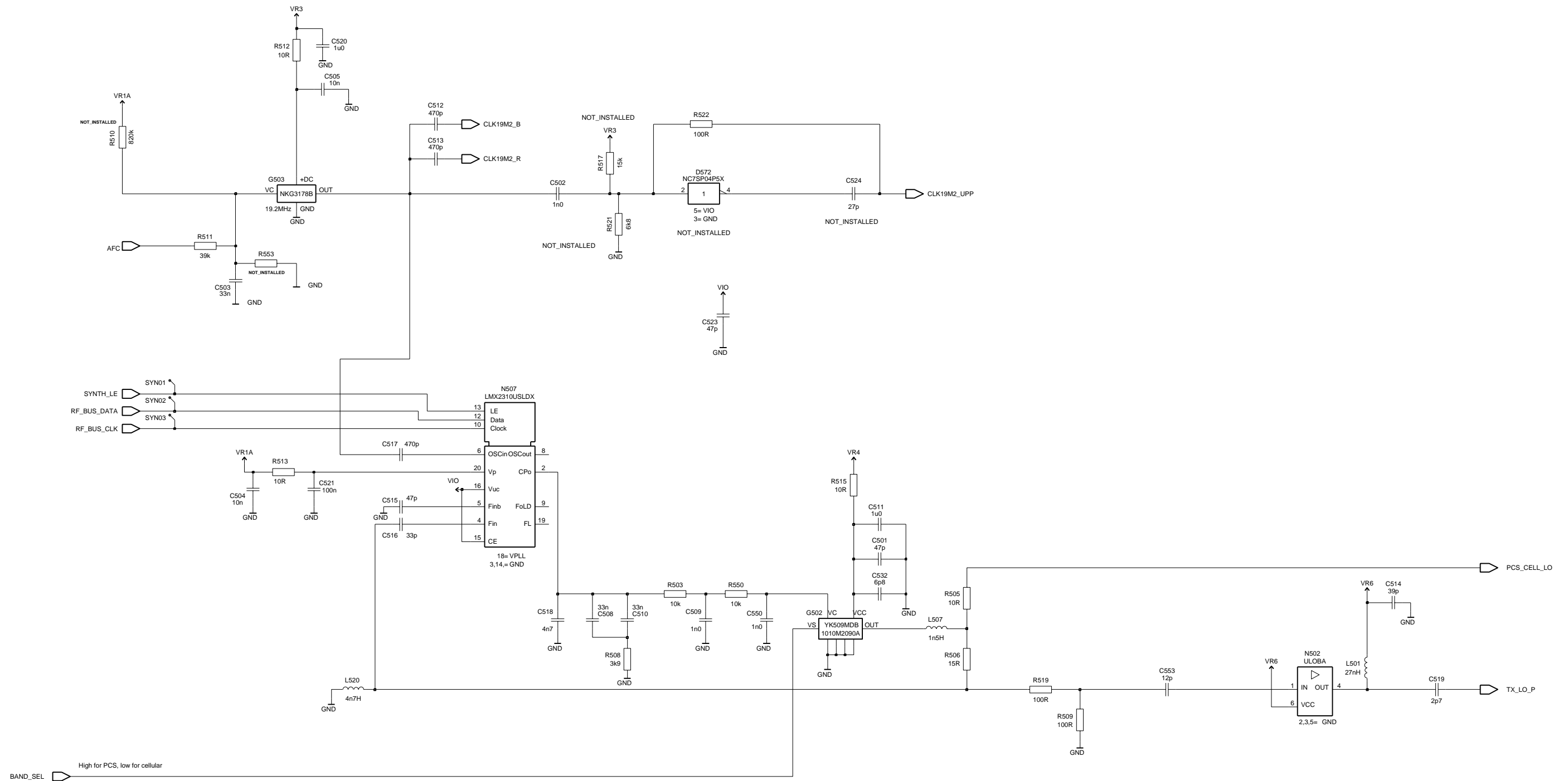

Batman

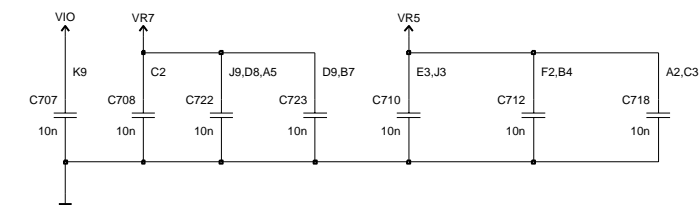
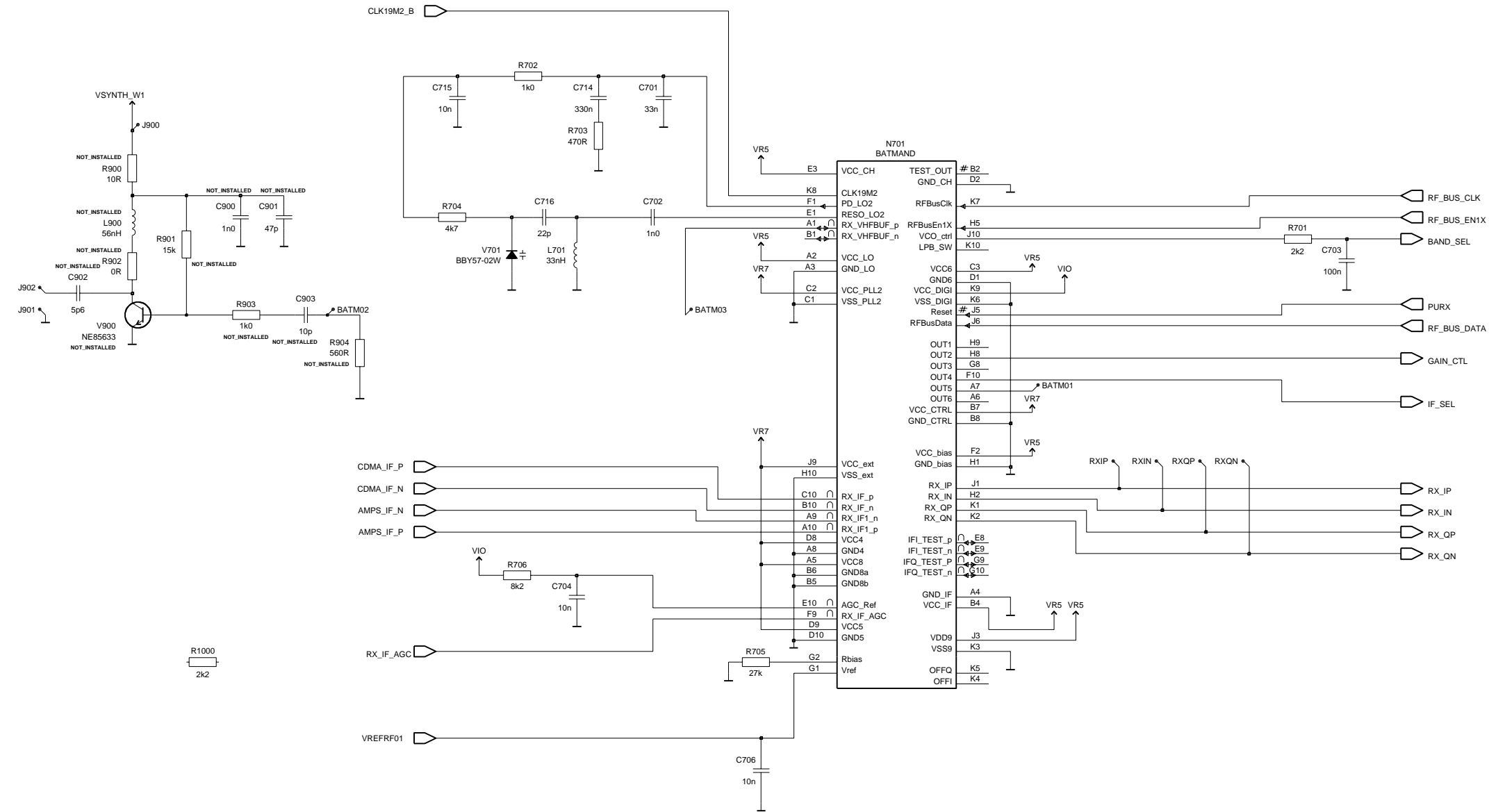

System Module

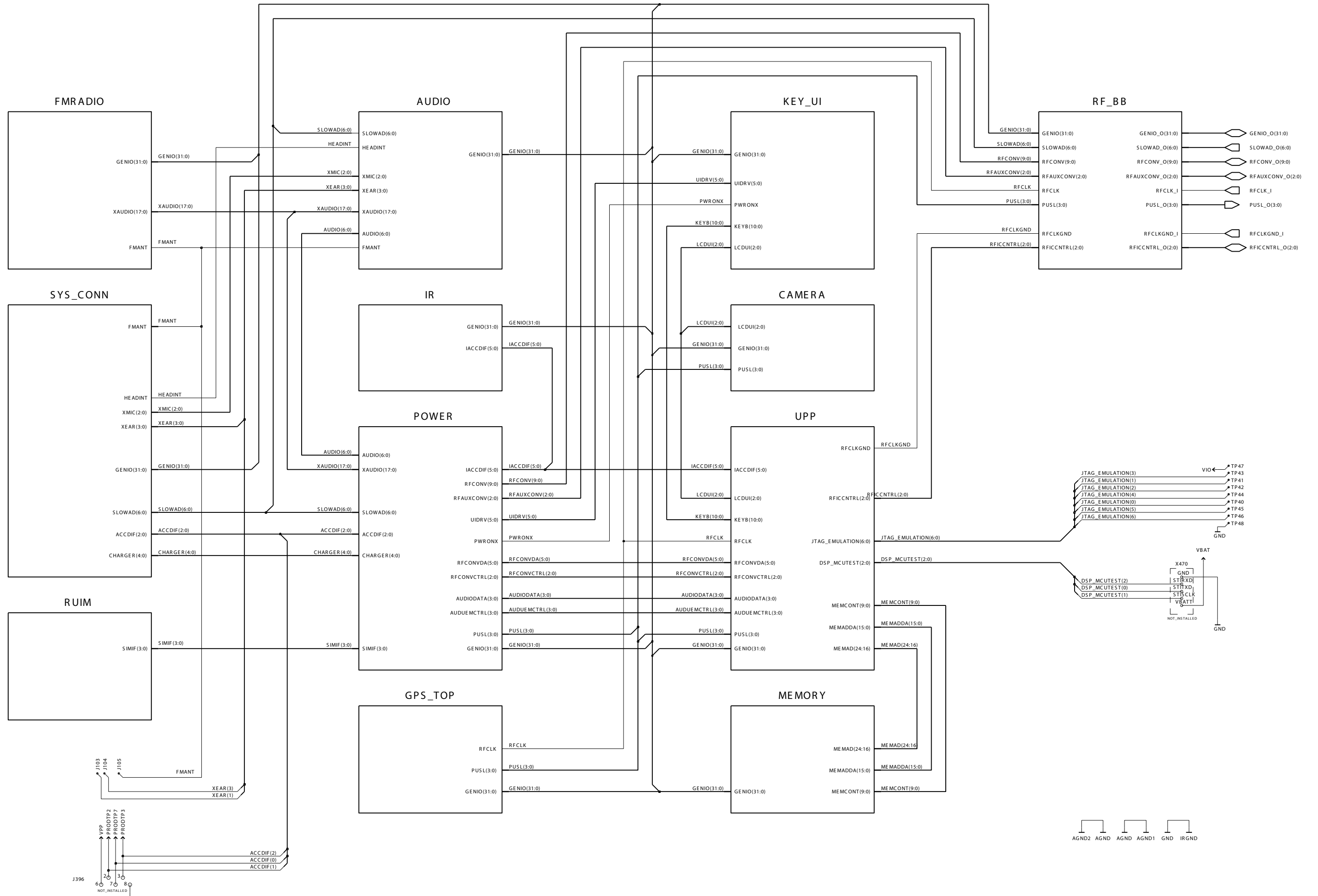

System Power

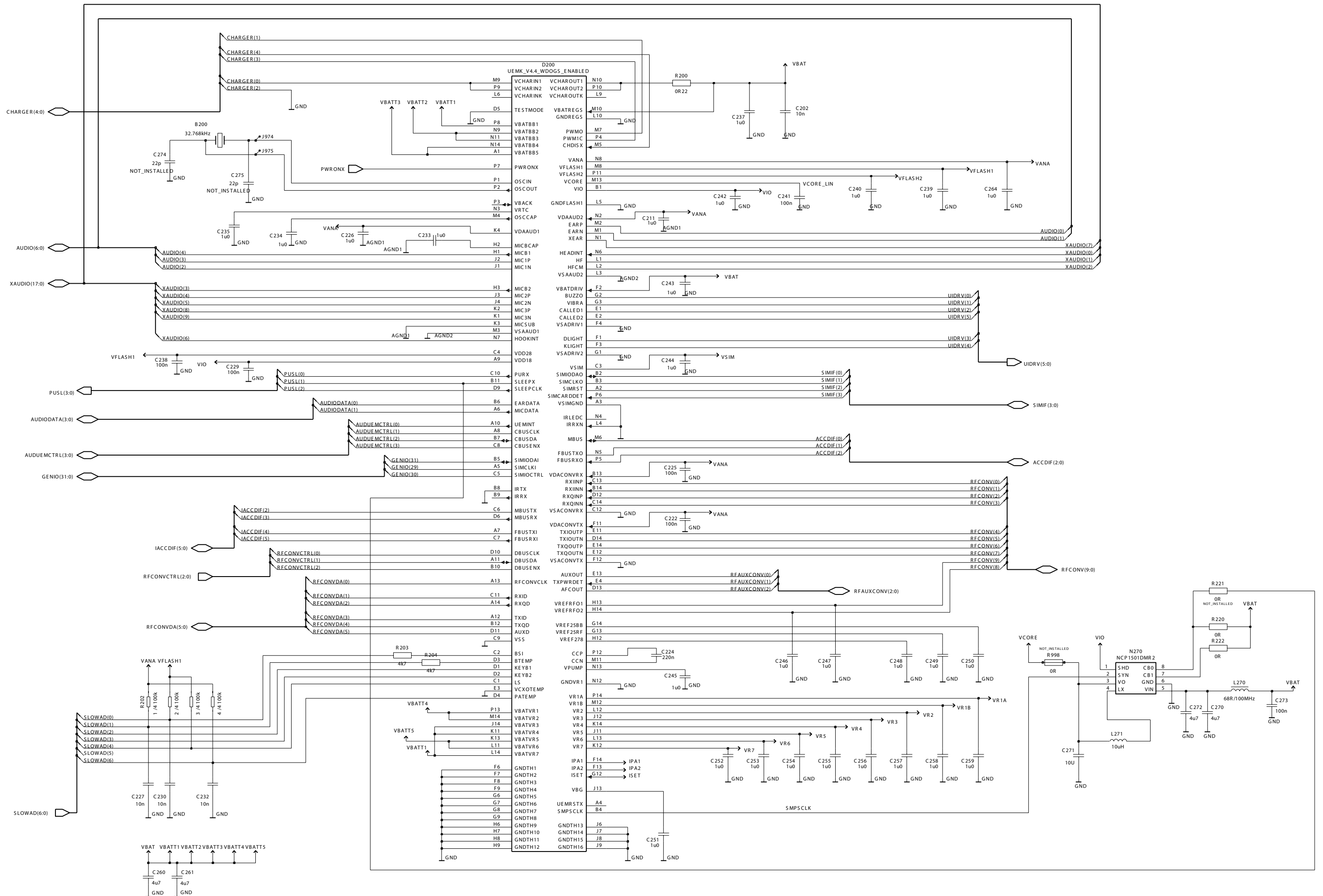

GPS RF-BB Interface

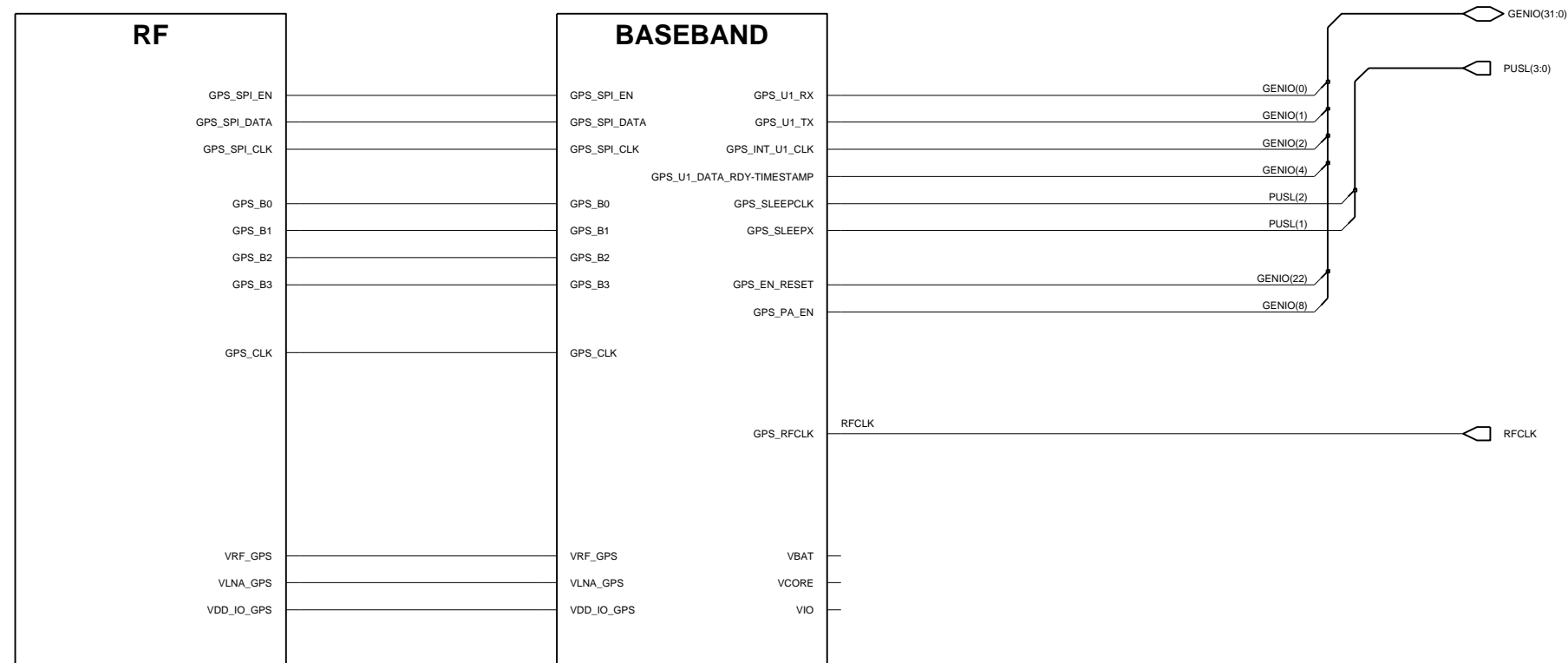

GPS Baseband Circuit Diagram

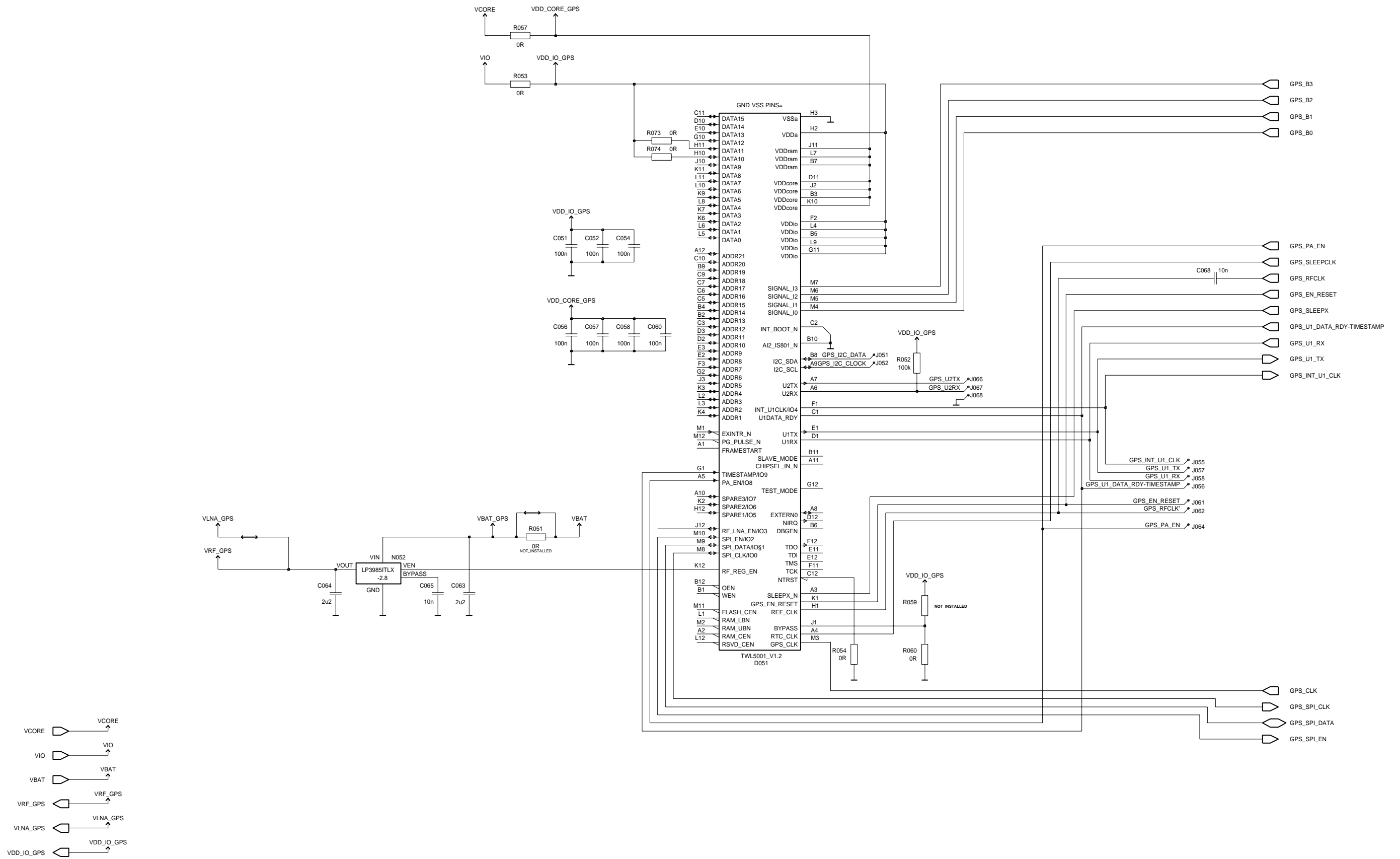

GPS RF Circuit Diagram

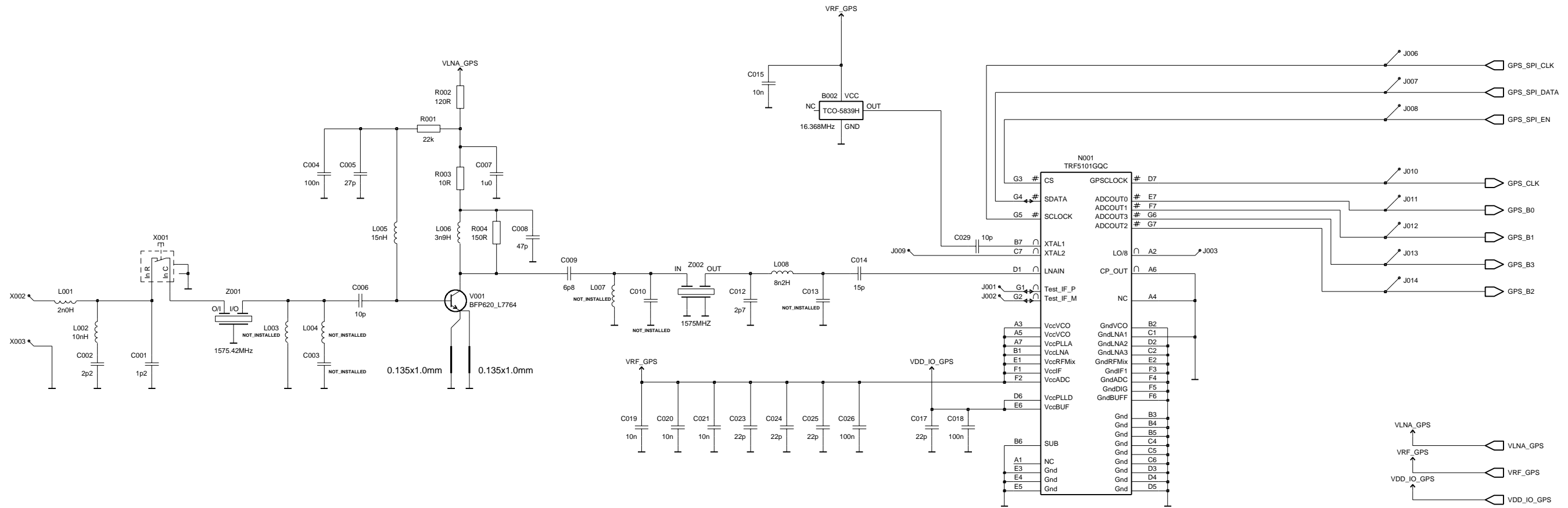

UPP 8M Implementation

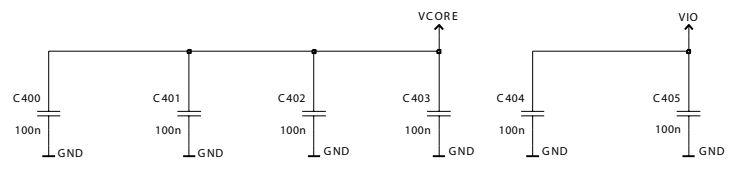
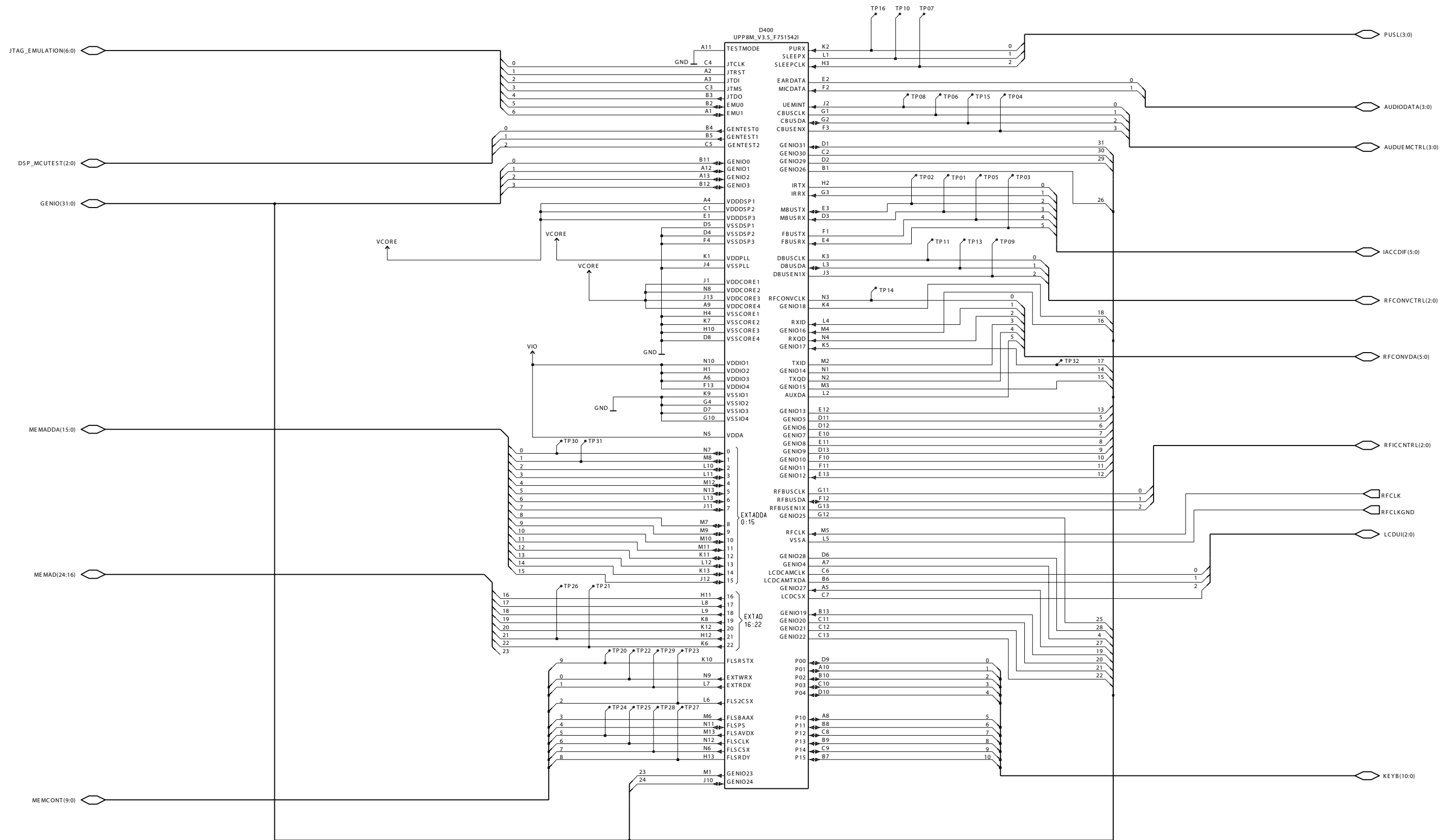

AMD 64-Mbit (Burst Read/Write) Memory

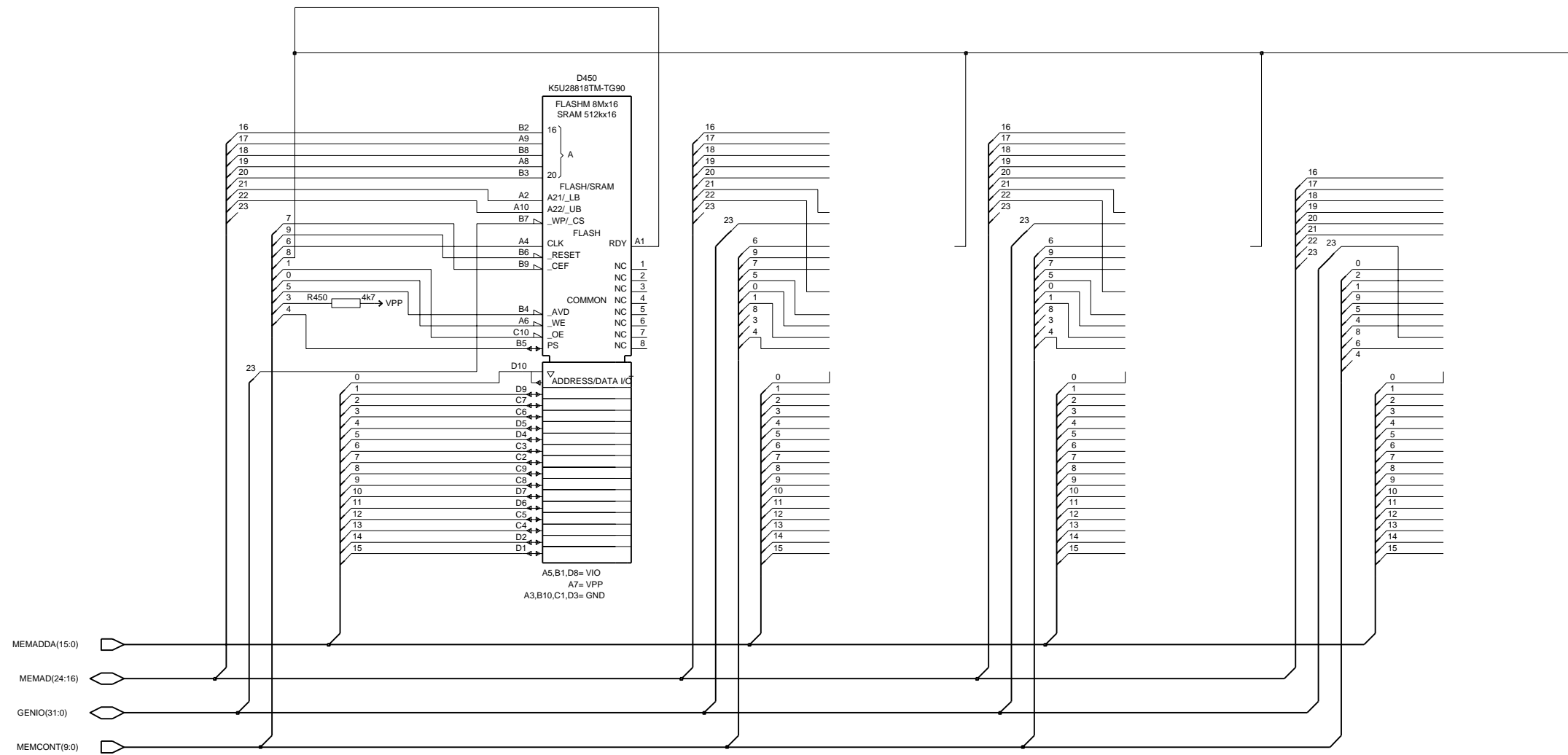

User Interface

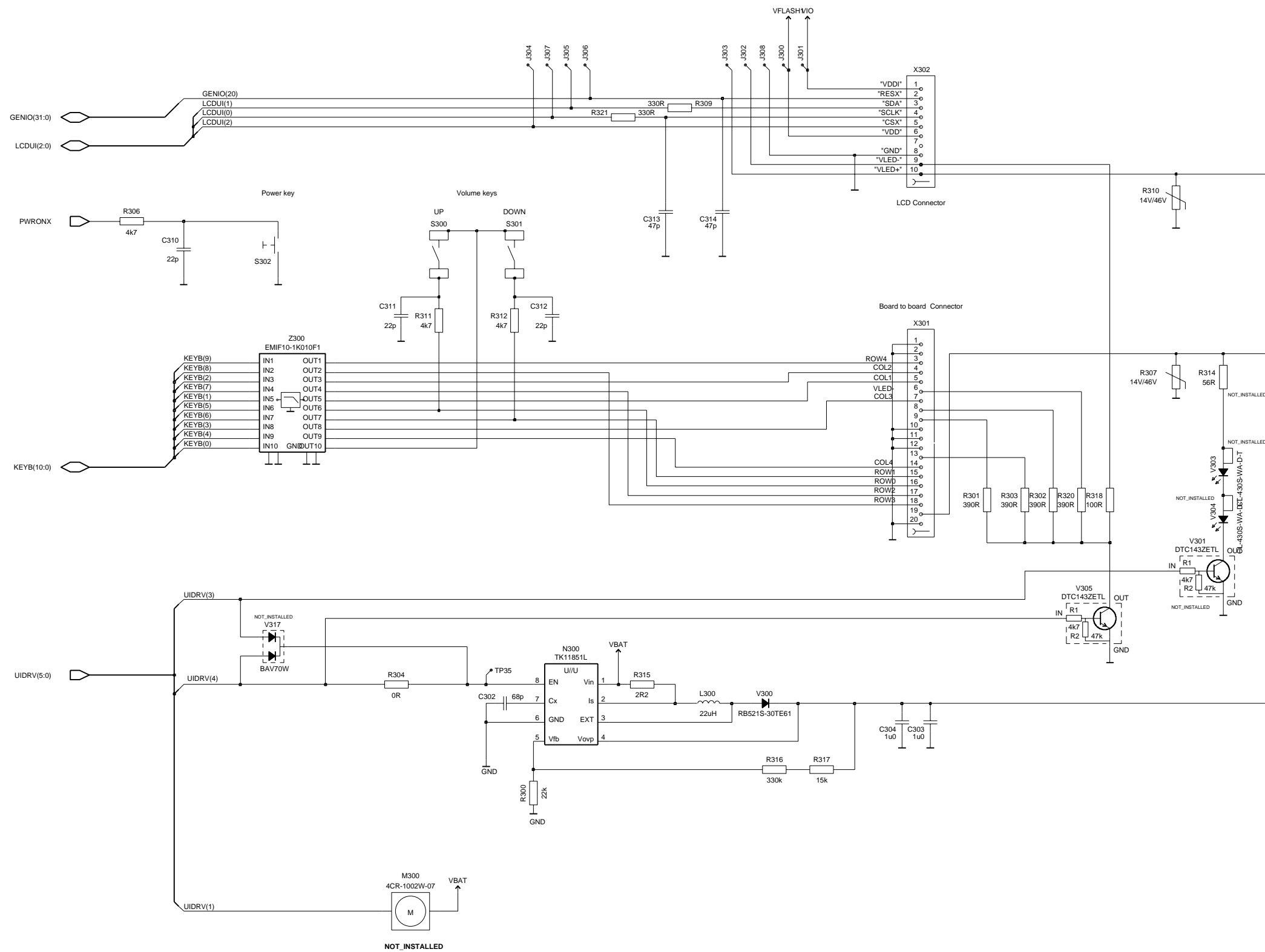

System Connector

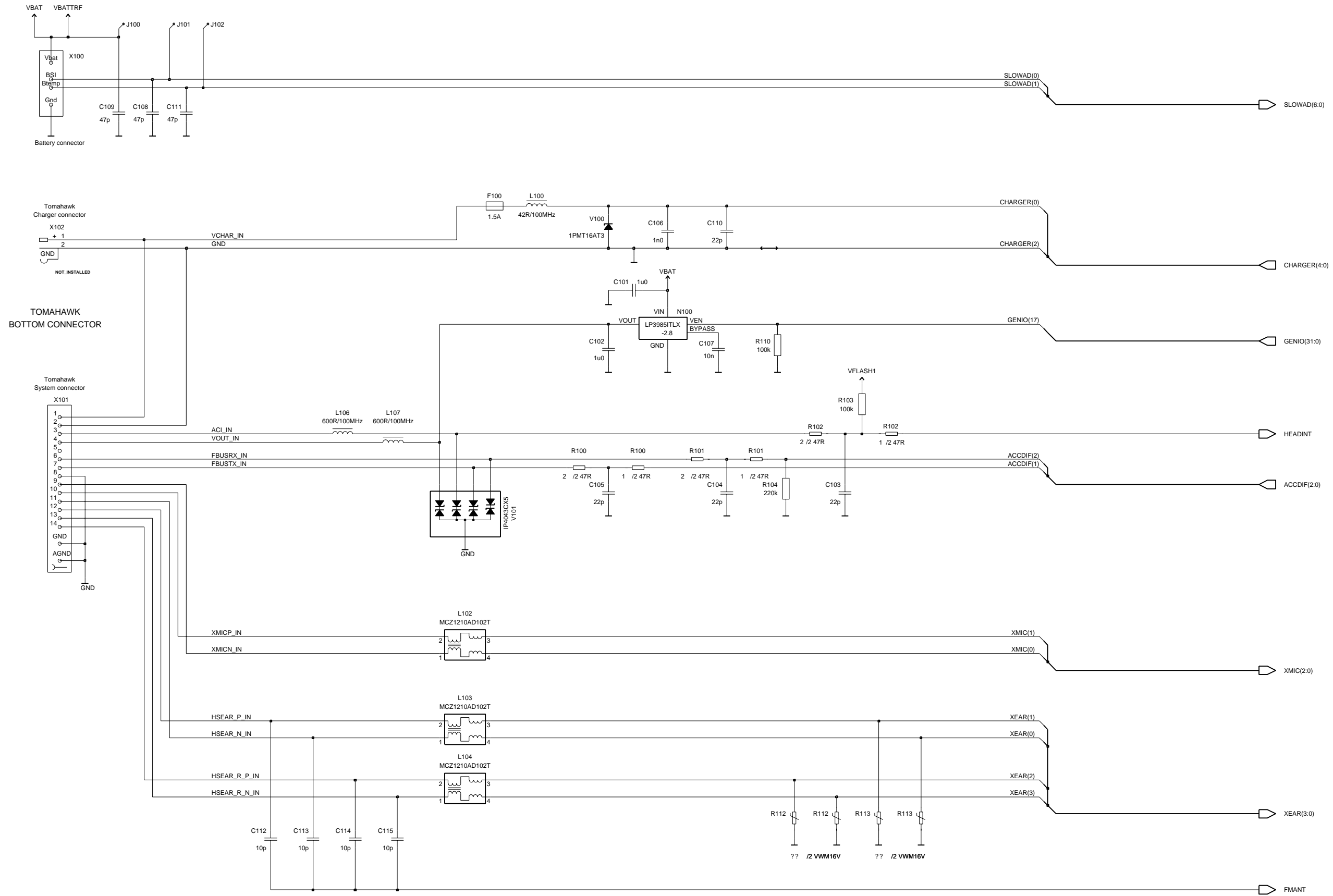

BB-RF Interface

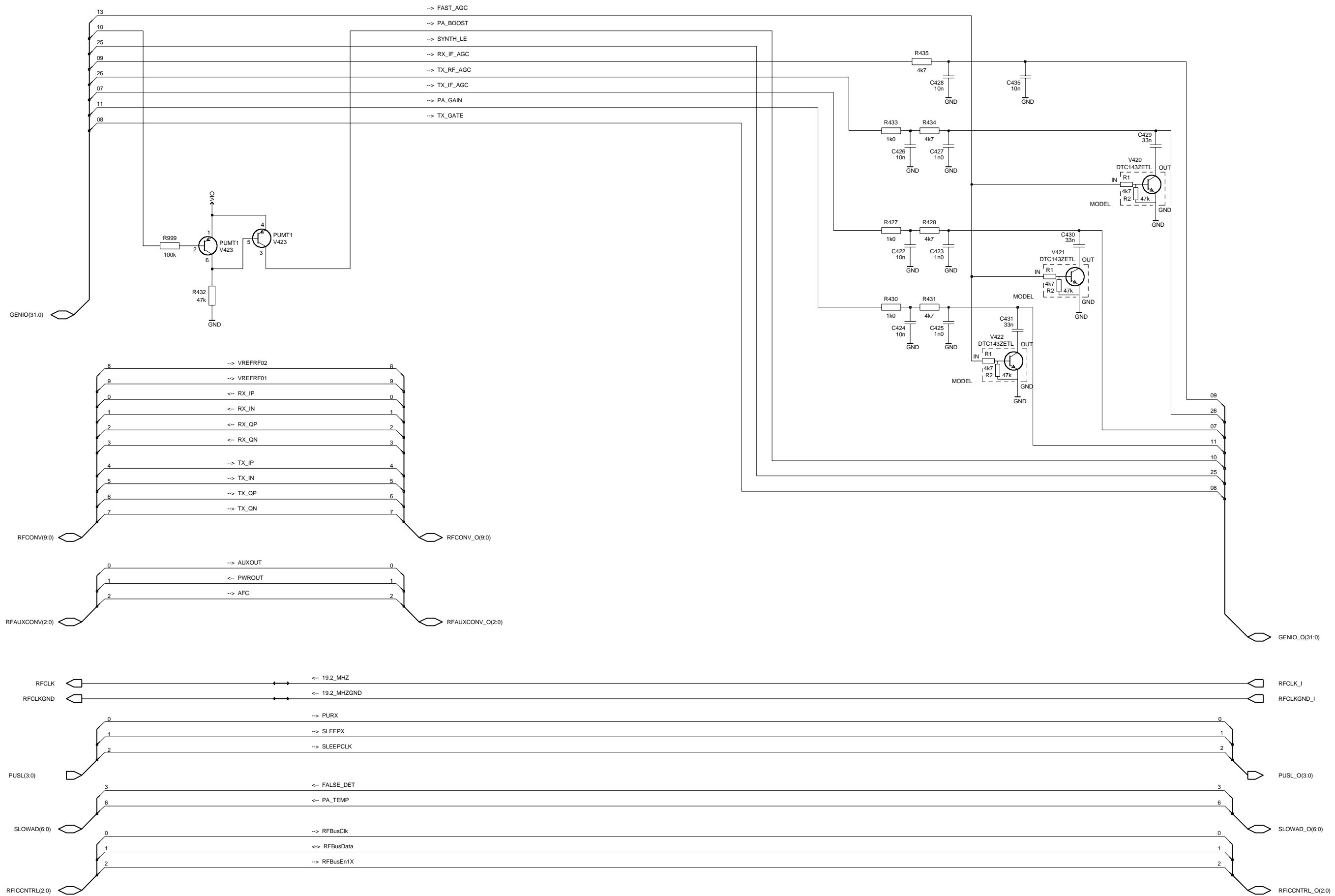

Component Layout — Top View

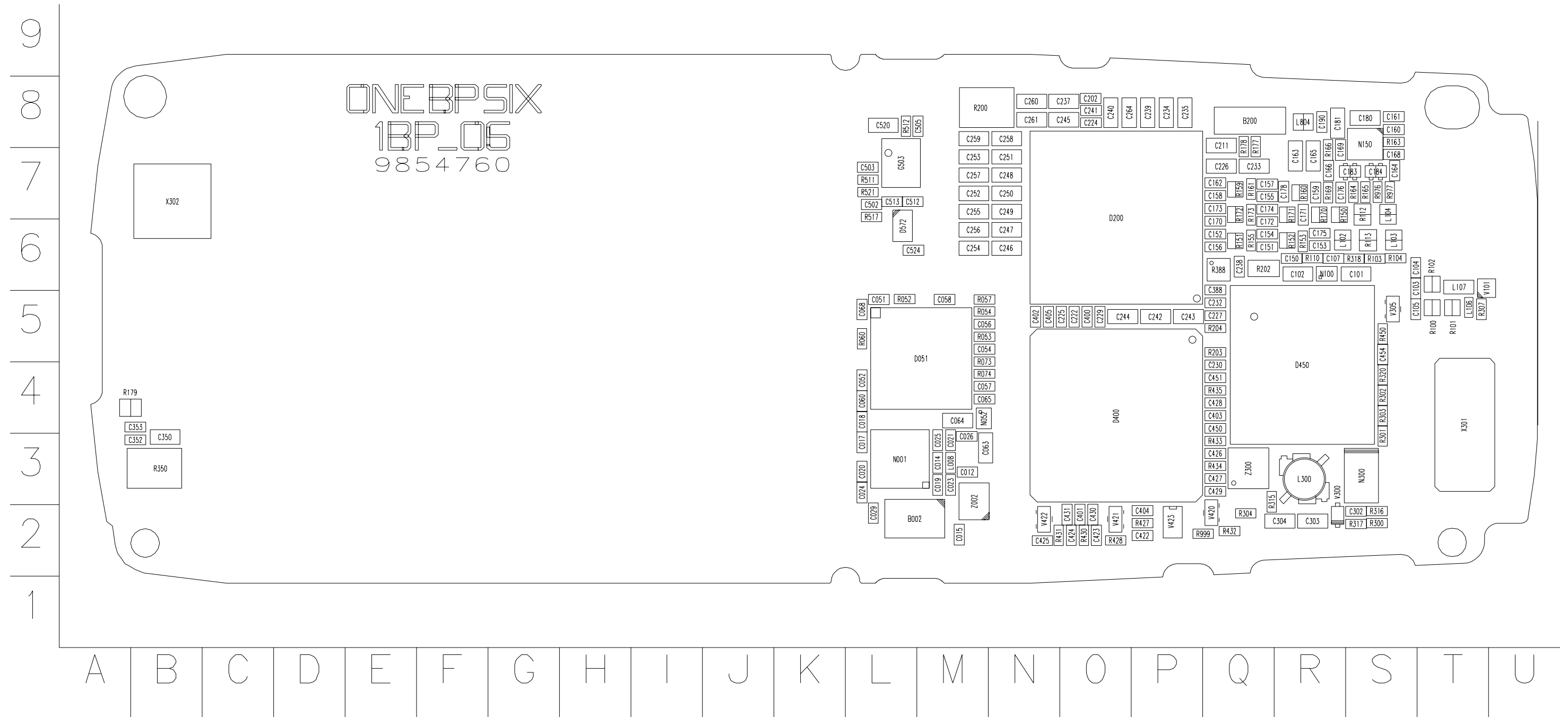

Component Layout — Bottom View

